

CMOS 4-BIT SINGLE CHIP MICROCOMPUTER  
**S5U1C63000H2** Manual  
(S1C63 Family In-Circuit Emulator)

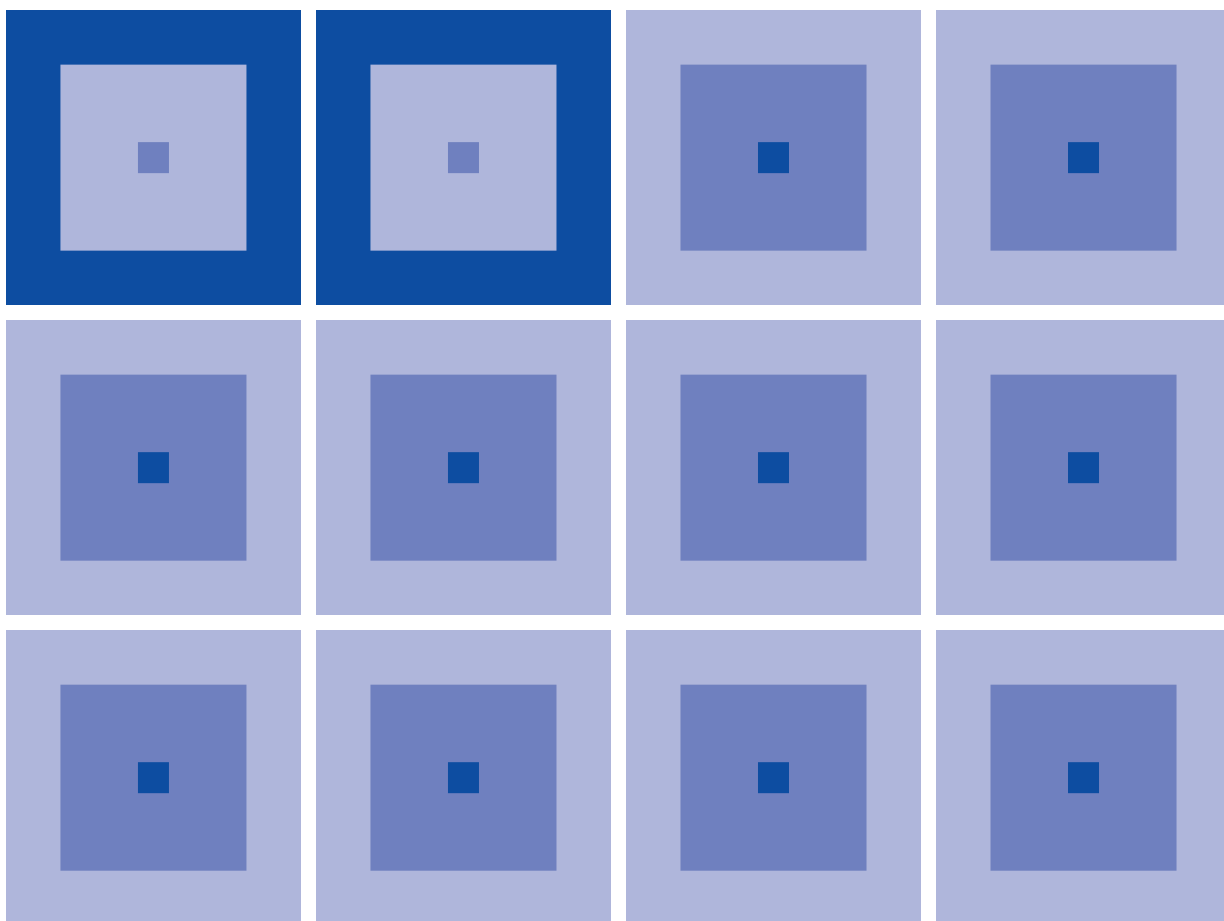

## ***NOTICE***

---

*No part of this material may be reproduced or duplicated in any form or by any means without the written permission of Seiko Epson. Seiko Epson reserves the right to make changes to this material without notice. Seiko Epson does not assume any liability of any kind arising out of any inaccuracies contained in this material or due to its application or use in any product or circuit and, further, there is no representation that this material is applicable to products requiring high level reliability, such as medical products. Moreover, no license to any intellectual property rights is granted by implication or otherwise, and there is no representation or warranty that anything made in accordance with this material will be free from any patent or copyright infringement of a third party. This material or portions thereof may contain technology or the subject relating to strategic products under the control of the Foreign Exchange and Foreign Trade Law of Japan and may require an export license from the Ministry of International Trade and Industry or other approval from another government agency.*

MS-DOS, Windows, Windows 95, Windows 98 and Windows NT are registered trademarks of Microsoft Corporation, U.S.A.  
PC-DOS, PC/AT, PS/2, VGA, EGA and IBM are registered trademarks of International Business Machines Corporation, U.S.A.  
NEC PC-9800 Series and NEC are registered trademarks of NEC Corporation.  
All other product names mentioned herein are trademarks and/or registered trademarks of their respective owners.

## New configuration of product number

Starting April 1, 2001, the product number has been changed as listed below. Please use the new product number when you place an order. For further information, please contact Epson sales representative.

### Devices

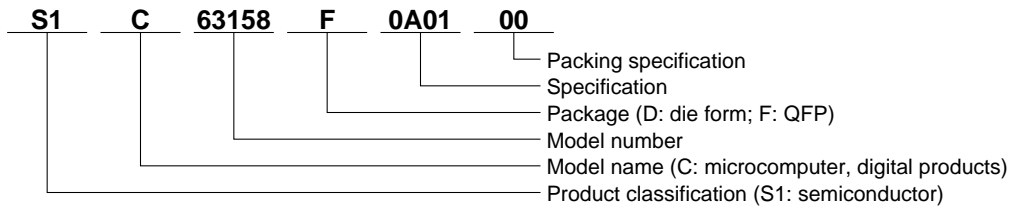

### Development tools

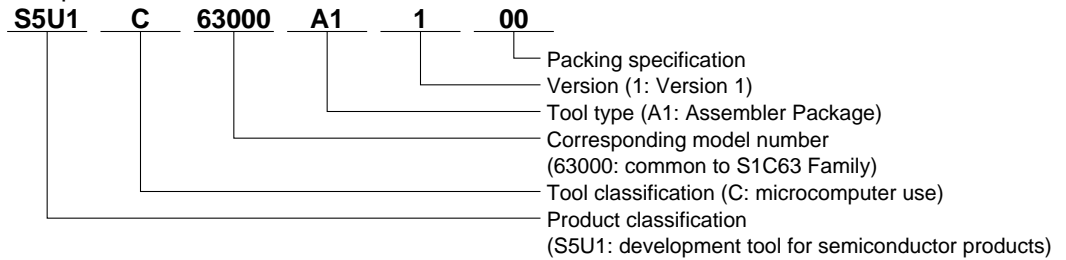



## CONTENTS

<b>CHAPTER 1</b>	<b>INTRODUCTION</b>	<b>1</b>
<b>CHAPTER 2</b>	<b>S5U1C63000H2 PACKAGE</b>	<b>2</b>
2.1	Components	2
2.2	Component Specifications	3
2.3	Environmental Conditions for Operation	3
2.4	Specifications of Operation Panels	4
2.5	Setting the Dip Switch	6
<b>CHAPTER 3</b>	<b>CONNECTION</b>	<b>7</b>
3.1	AC Cable	7
3.2	DC Cable	7
3.3	Connection with Host Personal Computer	7
3.4	Installing Peripheral Circuit Board (S5U1C63xxxP)	8
<b>CHAPTER 4</b>	<b>GETTING STARTED</b>	<b>9</b>
4.1	Operation in ICE Mode	9
4.2	Operation in Free Run Mode	9
<b>CHAPTER 5</b>	<b>OPERATION AND FUNCTION OF S5U1C63000H2</b>	<b>11</b>
5.1	General of Operation	11
5.2	Break Function	12
5.3	Monitoring Terminals	12
5.4	Display During Execution and During Break	13
5.5	Break Commands	13
5.6	Target Interrupt and Break	14
5.7	Trace Function	14
5.8	Trace Mode	15
5.9	Trace Trigger Point	15
5.10	Coverage Function	15
5.11	Measurement of Execution Time	15
5.12	Self Diagnosis Function	16
5.13	Restrictions on Emulation	16
<b>CHAPTER 6</b>	<b>NOTES ON USING</b>	<b>19</b>
6.1	Notes on Operations	19
6.2	Differences from Actual IC	19
<b>CHAPTER 7</b>	<b>MAINTENANCE AND WARRANTY</b>	<b>20</b>
7.1	Diagnosis Test	20
7.2	Warranty	20

**CHAPTER 8 TROUBLE SHOOTING** ..... **21**

**CHAPTER 9 SPECIFICATIONS OF LCD BOARD** ..... **22**

    9.1 Introduction ..... 22

        9.1.1 General description of LCD board ..... 22

        9.1.2 External view of LCD board ..... 22

    9.2 Precautions on Using ..... 23

        9.2.1 Notes on operations ..... 23

        9.2.2 Difference from an actual IC ..... 23

    9.3 Connection with Target System ..... 24

    9.4 Product Specifications ..... 26

# CHAPTER 1 INTRODUCTION

S5U1C63000H2 (In-Circuit Emulator for S1C63 Family) is a hardware tool to effectively develop software for the S1C63 Family, 4-bit single chip microcomputers. In combination with a peripheral circuit board (S5U1C63xxxP), it provides the development environment of the software using a personal computer as a host computer, which requires Windows.

This manual describes the operation of the S5U1C63000H2 hardware and connections of the S5U1C63000H2 system. Refer to "S5U1C63000A Manual" for use of the debugging commands.

Figure 1.1 shows the external view of the S5U1C63000H2.

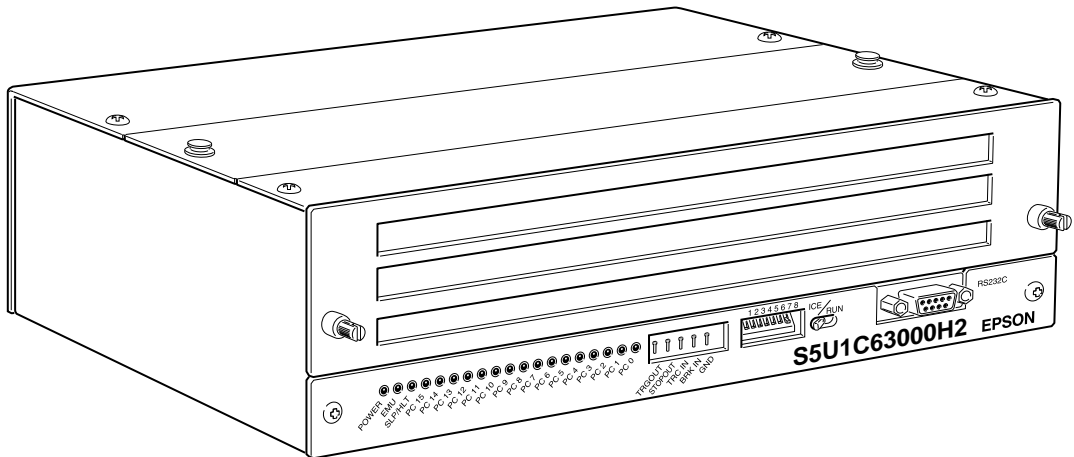

Fig. 1.1 External view of S5U1C63000H2

# CHAPTER 2 S5U1C63000H2 PACKAGE

## 2.1 Components

This package is in common with all models of the S1C63 Family. After unpacking the S5U1C63000H2 package, check to see that all of the following components are included.

Figure 2.1.1 shows the packing structure.

- (1) S5U1C63000H2 (main unit with LCD board) ..... 1 unit
- (2) RS232C cable (for IBM PC/AT) ..... 1 cable
- (3) AC adapter ..... 1 pcs.
- (4) AC cable ..... 1 cable
- (5) Jig for installing/dismounting board ..... 2 pcs.
- (6) S5U1C63000H2 Manual (S1C63 Family In-Circuit Emulator) ..... 1 copy (this manual)
- (7) Flat cable with 50-pin × 2 connectors ..... 1 pair
- (8) Flat cable with 34-pin connector ..... 1 cable
- (9) 50-pin connector for target system ..... 2 pcs.
- (10) 34-pin connector for target system ..... 1 pcs.
- (11) User registration card ..... 1 card
- (12) Warranty card ..... 1 card
- (13) Precautions on using the S5U1C63000H2 ..... 1 sheet

*Note: Following items need to be provided separately, not included in this package.*

- (14) S5U1C63xxxP board (included in the S5U1C63xxxP package)
- (15) S5U1C63xxxP Manual (included in the S5U1C63xxxP package)
- (16) S1C63 Family Debugger (included in the S1C63 Family Assembler package)
- (17) S5U1C63000A Manual (included in the S1C63 Family Assembler package)

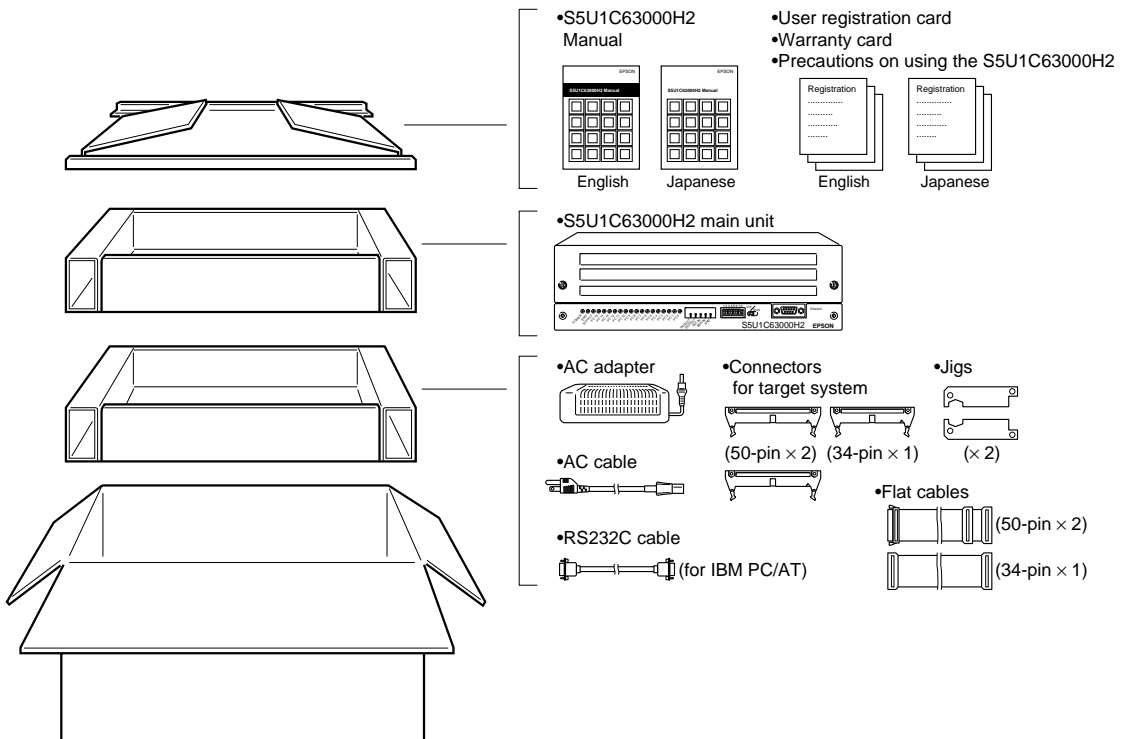

Fig. 2.1.1 Packing structure

## 2.2 Component Specifications

Table 2.2.1 shows the specifications of the component in the S5U1C63000H2 package.

Table 2.2.1 Specifications of S5U1C63000H2 components

No.	Components	Items	Specifications	Remarks
1	S5U1C63000H2	Dimensions	282 (W) × 177 (L) × 90 (H)	Rubber feet included
		Weight	Approx. 3.5 kg (main body)	
		External color	Cygnus white	
		Input voltage	DC 5 V	
		Power consumption	2 A, max.	
		Board mounted	ICE board and LCD board	*
2	RS232C cable (for IBM PC/AT)	Length	3 m	
		Interface level	EIA-RS232C level	
		Cable	12-pair shielded cable	
		Cable-ended connector	DEU 9S-F0	
		Connector on host	DE-9P	or equivalent
3	AC adapter	Dimensions	160 × 80 × 60	
		Input voltage	AC 90 V to 264 V	
		Input frequency	47 Hz to 63 Hz	
		Power consumption	25 W, max. (in ICE system load)	
		Output voltage•current	DC 5 V/5 A, with over current protection	Outside: 5 V, Inside: 0 V
4	AC cable	Length	1.8 m	
		Plug type	Bipolar with ground	
5	Accessories	Jig	for installing/dismounting option boards	
6	Package	Dimensions	380 (W) × 260 (L) × 225 (H)	
		Materials	W carton, cardboard	
		Total weight of package	Approx. 5 kg	

\* Peripheral circuit board is sold separately

## 2.3 Environmental Conditions for Operation

Table 2.3.1 shows the environmental conditions to operate S5U1C63000H2 that has to be used.

Table 2.3.1 Environmental conditions

No.	Items	Specifications	Remarks
1	Operating temperature	5 to 40 °C	
2	Storage temperature	-10 to 60 °C	
3	Operating humidity	35 to 80%	
4	Storage humidity	20 to 90%	No condensation
5	Resistance to vibration	Operating: 0.25 m/S <sup>2</sup>	
		Transportation: 1 m/S <sup>2</sup>	

## 2.4 Specifications of Operation Panels

This section explains the operation of each switch. Figure 2.4.1 shows the external view of the panels.

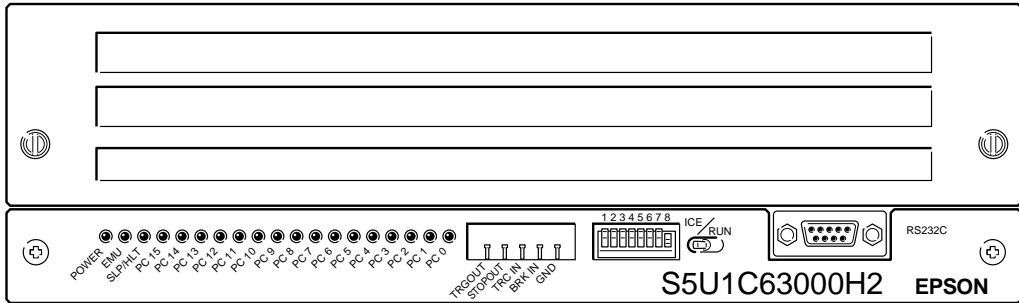

(Front view)

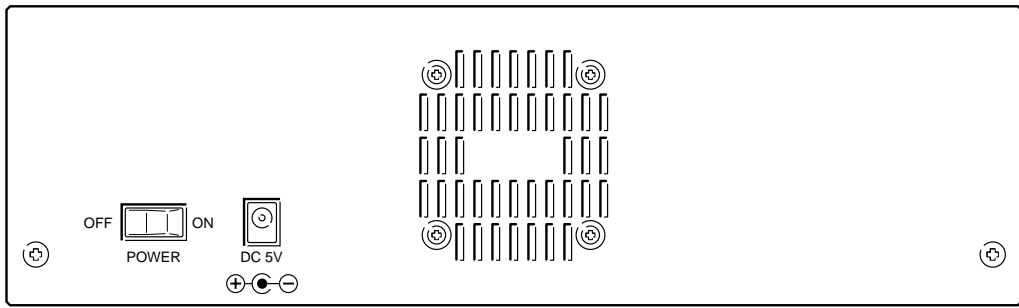

(Rear view)

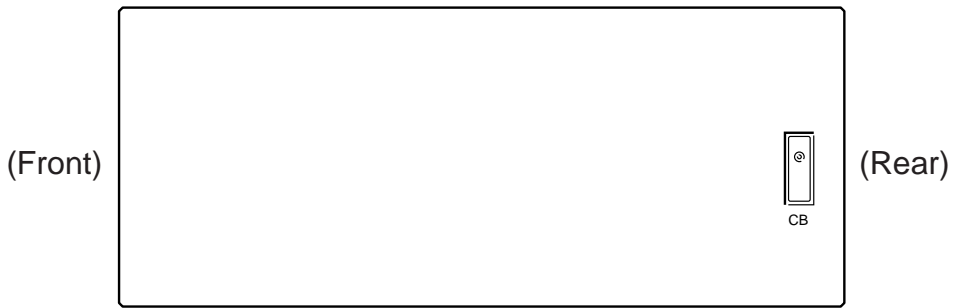

(Side view)

Fig. 2.4.1 External view of S5U1C63000H2 panels

Table 2.4.1 shows the function of each component on the panels.

Table 2.4.1 Function list of components

No.	Position	Indicated symbol	Name	Function
1	Side panel	CB	Circuit breaker	The breaker cuts off the power of the ICE system (ICE board, LCD board, peripheral circuit board and target board) at consumption current of 3 A or more. A small staff of the breaker comes up at the shut-off. The staff should be at the recessed position for normal operating status. The breaker does not work at the normal operation.
2	Front panel	ICE/RUN	ICE mode/Free run mode switch	Shifting the switch to "RUN" (slant to right) loads a target program from the flash memory in the S5U1C63000H2 without connection to a host computer and gets the system into free run status of the target program. In this mode, however, debugging function such as break and trace does not work. Shifting the switch to "ICE " (slant to left) enables the S5U1C63000H2 to be connected with a host computer and debugging function is operative through the debugger on the host computer.
3	Front panel	TRGOUT	Tracing trigger output terminal	Upon coincidence of trigger conditions with a tracing trigger point, a pulse is output from this terminal.
4	Front panel	STOPOUT	HALT/SLEEP status output terminal	When the S1C63000 CPU is in HALT or SLEEP status, low level signal is output from this terminal. This is used to measure execution rate of the CPU. At the break mode, low level signal is also output.
5	Front panel	TRCIN	Trace input terminal	Information is stored in the trace memory by connection with a signal of the target system.
6	Front panel	BRKIN	Break input terminal	A running program enters in break status by input a low level signal from the target system.
7	Front panel	GND	Ground terminal for above	In case the above terminal is monitored with such an oscilloscope, the GND line of the oscilloscope is connected to this terminal. This is also used as a GND in case the signals are input to the above terminals.
8	Front panel	DSW1-8	DIP switch	This is a switch to set a baud rate of communication with a host computer. 9600 bps has been set at ex-factory. Refer to Section 2.5 for details.
9	Front panel	POWER	Power-on LED	This green LED lights upon power-on of S5U1C63000H2.
10	Front panel	EMU	Emulation LED	This red LED lights when the target program is in running status.
11	Front panel	SLP/HLT	Halt LED	This yellow LED lights when the S1C63000 CPU executes the HALT or SLP instruction. This LED also lights when the peripheral circuit board has not been installed.
12	Front panel	PC15-0	Program counter indicator	These LEDs indicate the program counter (PC) value while the program is running and also hold the PC value at the break point while the program is breaking.
13	Front panel	RS232C	RS232C connector	This is a connector to connect a RS232C cable. Tightening the connector with screws is recommended while using.
14	Rear panel	DC 5V	DC input connector	This is a connector to connect the DC cable of the AC adapter dedicated for S5U1C63000H2.
15	Rear panel	POWER	Power switch	Turns the S5U1C63000H2 power on and off.

## 2.5 Setting the Dip Switch

The S5U1C63000H2 works with a personal computer that runs Windows as a host. With a general computer that meets the condition, the serial transfer rate set at the factory (9600 bps) is good for use. In case the rate is changed, the transfer rate between the host computer can be changed by this switch. The switch also sets a self diagnostic function, which is equipped in the S5U1C63000H2, working or not working at the power on. Figure 2.5.1 shows the dip switch.

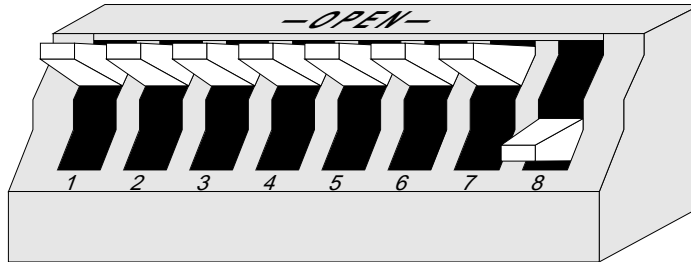

Fig. 2.5.1 Dip switch

### <Setting baud rate>

SW1-3	SW4	SW5	SW6	Baud rate setting
OPEN	OPEN	OPEN	OPEN	9600 bps, 8-bit character, 1 stop bit, no parity (factory setting)
OPEN	OPEN	ON	ON	2400 bps, 8-bit character, 1 stop bit, no parity
OPEN	ON	OPEN	ON	4800 bps, 8-bit character, 1 stop bit, no parity
OPEN	OPEN	OPEN	ON	19200 bps, 8-bit character, 1 stop bit, no parity
OPEN	ON	ON	OPEN	38400 bps, 8-bit character, 1 stop bit, no parity
Other settings			Do not set.	

Note: The setting at the host end is recommended to be "9600 bps, 8-bit character, 1 stop bit, no parity".

### <Setting the self diagnostic function>

SW8	Setting
OPEN	Self diagnosis On
ON	Self diagnosis Off (factory setting)

Note: When the S5U1C63000H2 is started with the self diagnosis on, it takes approx. 5 minutes to be ready for use.

Open means that the switch lever is at upper side.

On means that it is at lower side.

# CHAPTER 3 CONNECTION

This chapter describes the connection between the S5U1C63000H2 and a host computer and the Peripheral circuit board (S5U1C63xxxP).

## 3.1 AC Cable

The S5U1C63000H2 package includes a dedicated AC cable (3 poles type) and an AC adapter. The AC cable is connected into the AC inlet on the AC adapter. The common ground frame line should be used for connecting the S5U1C63000H2 and the host computer as shown in Figure 3.1.1.

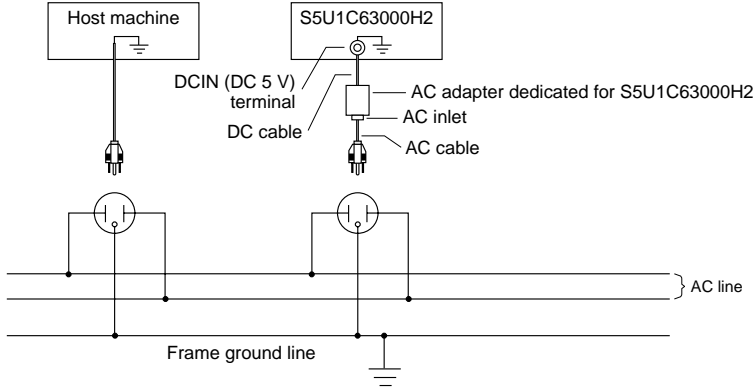

Fig. 3.1.1 Connection of AC line

## 3.2 DC Cable

The DC output cable of the AC adapter is connected to the DCIN (DC 5 V input) terminal as shown in Figure 3.1.1.

## 3.3 Connection with Host Personal Computer

Figure 3.3.1 shows the external view of the RS232C cable connector and Table 3.3.1 shows the signal specifications of the RS232C cable.

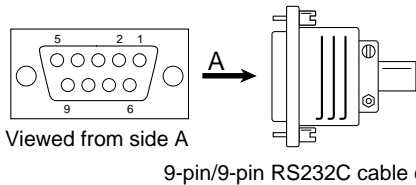

Fig. 3.3.1 External view of the RS232C cable connector

Table 3.3.1 Signal specifications

Terminal No.	Signal name	Signal meaning	Remarks
3	TXD	Transmit data from HOST to ICE	
2	RXD	Receive data from ICE to HOST	
7	RTS	Request to send from HOST	Normally used as ON
8	CTS	Clear to send from ICE	Normally used as ON
5	SG	Signal ground	

Connect S5U1C63000H2 to the personal computer using the supplied RS232C cable and tighten the connector screws to fix the cable.

### 3.4 Installing Peripheral Circuit Board (S5U1C63xxxP)

By installing the S5U1C63xxxP peripheral circuit board (to be separately sold) into a slot of the S5U1C63000H2, a debug system can be made corresponding to each device of the S1C63 Family. Figure 3.4.1 shows installing method of the peripheral circuit board. The S5U1C63000H2 is equipped with a main control board and a LCD drive board.

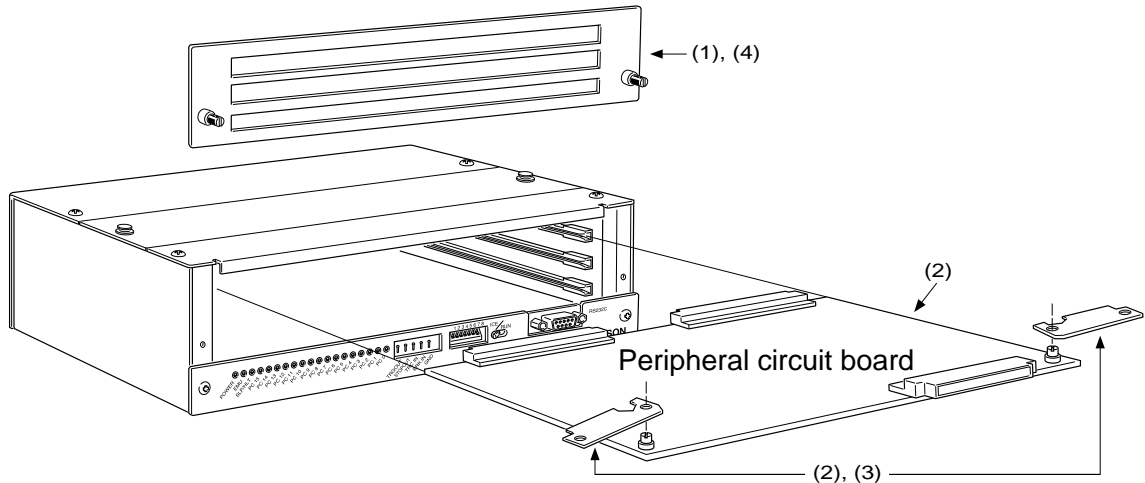

Fig. 3.4.1 Installing method of the peripheral circuit board

(1) Unfasten the screws located on the left and right sides of the front panel of the S5U1C63000H2 by turning them counterclockwise, then remove the front panel.

(2) Insert the peripheral circuit board into the uppermost slot and push it using the jig attached with the S5U1C63000H2 as shown in Figure 3.4.2.

Using this jig as a lever, push it toward the inside of the board evenly on the left and right sides. After confirming that the peripheral circuit board has been firmly fitted into the internal slot of the S5U1C63000H2, remove the jig.

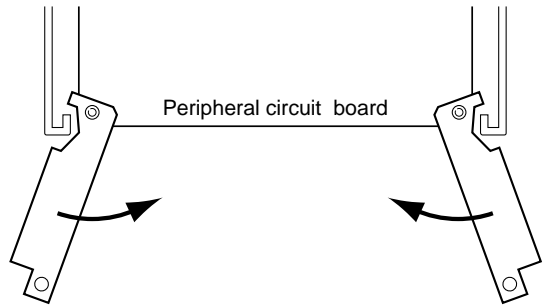

Fig. 3.4.2 Installing the peripheral circuit board

(3) Dismounting peripheral circuit board  
Set the jig into position as shown in Figure 3.4.3. Using this jig as a lever, push it toward the outside of the board evenly on the left and right sides and pull the peripheral circuit board out of the S5U1C63000H2.

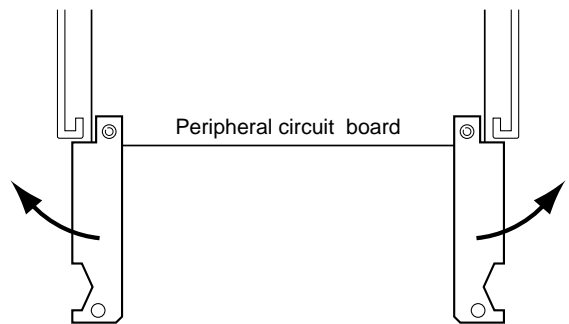

Fig. 3.4.3 Dismounting the peripheral circuit board

(4) Mounting the front panel  
Mount the front panel removed at the step (1) on the main case by pushing and turning two screws located at both side.

(5) The jig has a magnet for keeping under the bottom plate of the case while not in use.

# CHAPTER 4 GETTING STARTED

There are two operation modes in the S5U1C63000H2. One is ICE mode to be started with the debugger in connection with a host machine (the ICE/RUN switch on the front panel is set to ICE side) and the other one is free run mode to run a target program without a host machine (the ICE/RUN switch is set to RUN side).

## 4.1 Operation in ICE Mode

---

After the S5U1C63000H2 and the host machine is connected with the RS232C cable and the ICE/RUN switch is set to ICE side, turn the host machine and S5U1C63000H2 power on. It enables the S5U1C63000H2 to be controllable by the host machine and the debugger can be executed on the host. Following shows the operation sequence of the S5U1C63000H2 after power-on.

### (1) Turning the S5U1C63000H2 power on

The power LED (green) is on, and the SLP/HLT LED (yellow) is momentary on. The PC8 and PC4 LEDs (red) go on (program counter is 110H).

### (2) Starting the debugger

Upon starting the debugger on the host, the SLP/HLT LED (yellow) goes momentary on.

### (3) Execution of a target program

When the debugger starts execution of a target program, the EMU LED (red) is turned on to indicate the emulation mode. While the target program is executed, the PC LEDs (red) indicate the current program counter value. When the SLP or HLT instruction is executed, the SLP/HLT LED (yellow) goes on and the PC LEDs (red) stop.

### (4) Occurrence of a break

When the target program stops at the break point set with the debugger, the EMU LED (red) goes off and the PC LEDs (red) stops at the break address. The break address means the program counter of next execution.

## 4.2 Operation in Free Run Mode

---

By turning the S5U1C63000H2 power on after the ICE/RUN switch located on the front panel is set to RUN side, the S5U1C63000H2 enters in the free run mode that executes the target program continuously. Following shows the execution flow of the target program in the free run mode.

### (1) Turning the S5U1C63000H2 power on

The power LED (green) is on, and the SLP/HLT LED (yellow) is momentary on. PC8 and PC4 LEDs (red) go on (program counter is 110H).

### (2) Setting data from flash memory

The S5U1C63000H2 read the configuration information and various mask option information for each model from the built-in flash memory and set them to the controller. The target program is also read from the flash memory and transferred to the built-in emulation memory.

### (3) Execution of the target program

The S5U1C63000H2 executes the target program from the reset address. The PC LEDs (red) indicate the current program counter position during execution. When the SLP or HALT instruction is executed, the SLP/HLT LED (yellow) goes on and the PC LEDs (red) stop.

● **Notes on free run mode**

- (1) Any configuration information, various mask information and target program have not been written in the flash memory built into the S5U1C63000H2 at the time of ex-factory. Even though the S5U1C63000H2 enters in the free run mode without the data, it does not execute any target program and while the program counter on the front panel indicates the reset address of 110H. Therefore, it is necessary to write a target program, configuration information and various mask option information into the flash memory in the ICE mode before setting the free run mode.
- (2) In the free run mode, the break functions and the trace functions can not be used. The free run mode only execute a target program and display the current program counter with the LEDs on the front panel. The BRKIN terminal on the front panel becomes invalid.
- (3) In the case any incorrect access exceeding configured program size or data RAM size is occurred by reason of a improper target program, the S5U1C63000H2 immediately stops at the program counter, where the incorrect access is made, by the LEDs on the front panel. In order to reset this situation, the power should be off. Before the free run of the target program is carried out again, the program must be completely debugged on the ICE mode. In the case any control to exceed program sizes such as jump or call to outside of the program, it stops before the access to an incorrect area. In the case any control to exceed data size such as read or write into outside of the data RAM area, it stops after the access to the incorrect area.
- (4) The S5U1C63000H2 may takes approx. 5 minuets after it is turned on until it starts execution of the target program.

# CHAPTER 5 OPERATION AND FUNCTION OF S5U1C63000H2

This chapter describes operations, functions in detail and restrictions in the emulation mode of the S5U1C63000H2.

## 5.1 General of Operation

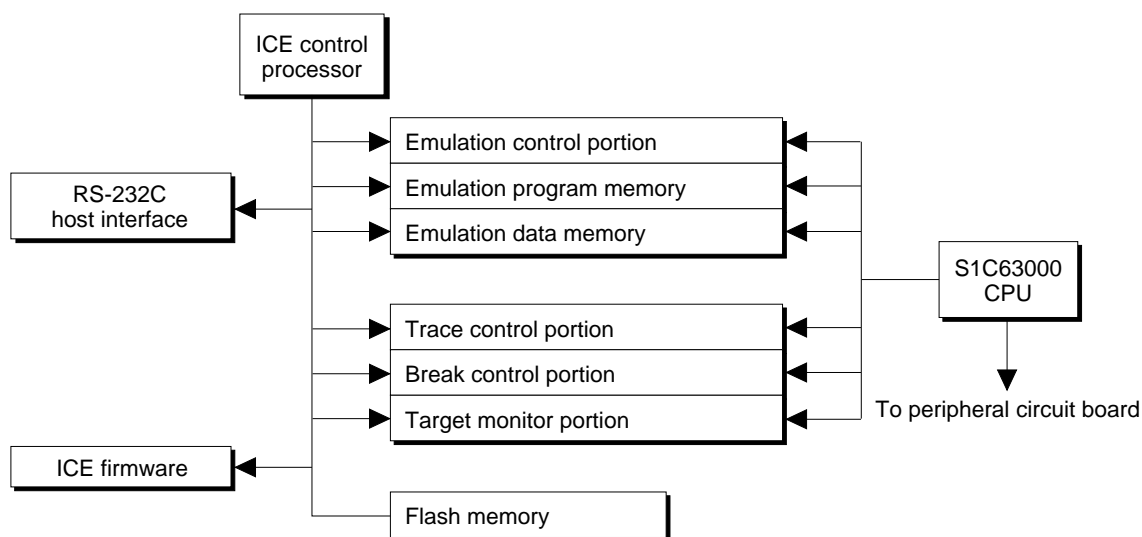

Fig. 5.1.1 Functional block diagram of S5U1C63000H2

Figure 5.1.1 shows the functional block diagram of the S5U1C63000H2.

The S5U1C63000H2 has a processor to control in-circuit emulation, which processes the ICE commands. The function to execute or stop target programs by the S1C63000 CPU is called emulation, of which control is done by the emulation control portion.

Operation that the S1C63000 CPU is working (specified by the G command) and single step operation (specified by the S or N commands) are called emulation mode, on which the EMU LED goes on and program counter display LEDs real timely indicate the program counter of the program running. The other status is called standby mode, which turns the EMU LED off and makes the program counter display LEDs show program counter position at the break.

The target program to be executed with the S1C63000 CPU is stored in the emulation program memory and data RAM area of the S1C63000 CPU is assigned to the emulation data memory. Loading a program from the flash memory or the host is done by the S5U1C63000H2 control processor in the standby mode. The trace control portion records execution bus cycle of the S1C63000 CPU and consists of a memory of 8,192 words × 120 bits. Such large size memory enables the register value inside the S1C63000 CPU to be real timely recorded. The tracing is done in the emulation mode and it is analyzed by the S5U1C63000H2 control processor in the standby mode.

The break control portion compares the bus condition of the S1C63000 CPU with break points and stops the execution of the target program upon coincident. The break can be also real timely made by register values of the S1C63000 CPU. While a target program is running, the target monitor portion of the S5U1C63000H2 control processor monitors executing program counter value of the S1C63000 CPU and RAM contents at watching points. The monitored result is displayed as on-the-fly information. The S1C63000 CPU can real timely execute the target program while the information is displayed.

## 5.2 Break Function

- **Forced break**

The debugger on the host machine can forced break the emulation. This function is useful when the program counter does not proceed by executing the SLP or HALT instruction in a single step process.

- **Break commands**

Some break commands are available to set various breaking conditions. A break occurs when the break condition specified by the command and status of the S1C63000 CPU are met.

- **Break by accessing to undefined area**

This break occurs when the target program accesses an address exceeding the ROM capacity of the actual chip. The break is also occurred when any address other than the RAM area or mapped I/O area of the actual chip is accessed.

- **Break by accessing write protect area**

This break occurs when the target program writes data to the read only memory such as a character generator ROM. The memory contents are protected even this break occurs.

- **Break by incorrect stack accessing**

This break occurs when the target program makes incorrectly stacking operation exceeding the defined stack area in the S1C63000 CPU.

- **BRKIN terminal**

When a signal is input to the BRKIN terminal, a break occurs at the falling edge of the signal.

## 5.3 Monitoring Terminals

- **TRGOUT output terminal**

A low level pulse is output at the T3 state of the clock when the trace trigger condition and the bus cycle are met.

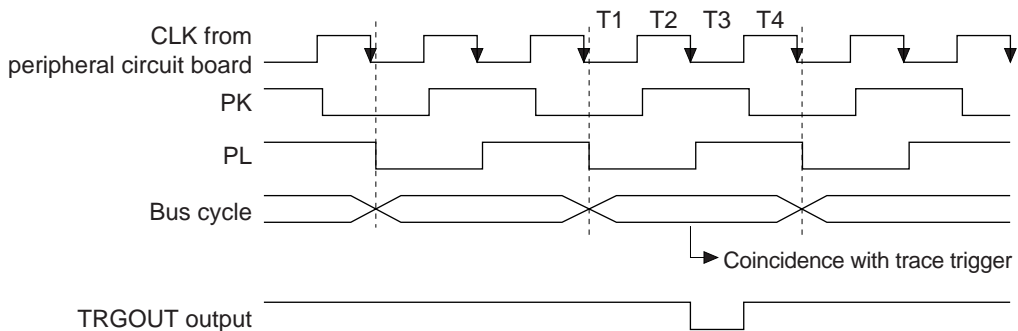

Fig. 5.3.1 TRGOUT terminal output

- **STOPOUT output terminal**

A low level is output when the S1C63000 CPU is suspended (by execution of the HALT or SLP instructions). This terminal also outputs low level during break.

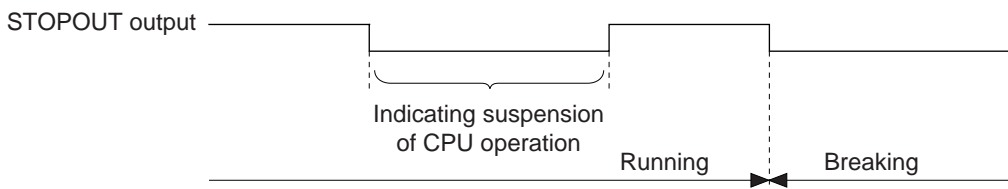

Fig. 5.3.2 STOPOUT terminal output

### ● TRCIN input terminal

By connecting a signal line of the target system to this terminal, trace information is stored into the trace memory. "1" is written to the trace memory when it is not connected or the signal is at high level, and "0" is written to the trace memory when the signal is at low level. The signal is sampled at the rising edge of T4 state.

### ● BRKIN input terminal

A break occurs when a low level signal is input to this terminal while the target program is running. To use this terminal for the break function, the low level pulse must be 20 msec or longer. By connecting the TRGOUT output terminal to the BRKIN input terminal, breaks can occur according to the trace trigger conditions.

## 5.4 Display During Execution and During Break

---

The S5U1C63000H2 control processor monitors the execution status of the S1C63000 CPU while the target program is running. It displays the S1C63000 CPU's execution status in every 500 msec when the on-the-fly display mode is specified. Program counter value that are displayed during break show the address to be executed in next step. Values in all registers are at the time of the break.

The LED's (PC15-PC0) on the front panel indicate the executed program counter value during execution, and stops at the break address when a break occurs.

## 5.5 Break Commands

---

The S5U1C63000H2 has abundant break functions.

### (1) PC break

This break function is specified by the BP command. When the program counter of the S1C63000 CPU coincides with the specified address, a break occurs before executing the instruction. Multiple PC values (up to maximum size of program memory) can be specified as break points.

### (2) PC sequential break

This break function is specified by the BS command. The break occurs when the PC of the S1C63000 CPU counts three addresses in specified order. The pass count can be specified for the last address. The sequence (address 1 coincidence) → (address 2 coincidence) → (address 3 counted by specified times) breaks the execution.

### (3) Break by data access

This break function is specified by the BD command. The break occurs immediately after the target program accesses the data memory in the specified condition (AND condition of address, data and read/write operation). It is possible to specify a range for the address condition, a mask in bit units for the data condition and a mask for the read/write condition. This specification can set one break point only.

### (4) Break by register value

This break function is specified by the BR command. When the register values of the S1C63000 CPU coincides with the specified values, a break occurs immediately after the instruction is executed. An AND condition of A/B registers, E/I/C/Z flags and X/Y registers can be specified. It is also possible to specify masking on each register. This specification can set one break point only.

The above break functions, (1), (2), (3), (4), can be independently specified. When the target program is executed with all specified commands, BP, BS, BD, BR, breaks occur by meeting any condition.

### 5.6 Target Interrupt and Break

When an interrupt in the target program and a break are simultaneously occurred, the target interrupt is prioritized. The break occurs after completing the stack operation of the interrupt. The program counter at the break shows the top address of the interrupt handler routine. When the target program is restarted, it executes from the top address of the interrupt handler routine.

It is the same when "I (interrupt flag) = 1" is set as the break condition by the BR command. The break occurs when the I flag goes 1. However if an interrupt occurs simultaneously, the contents of the flags after the break is displayed as "EICZ:0000" (the I flag is reset) because of the prioritized interrupt process.

### 5.7 Trace Function

In the execution of the emulation mode, information of the S1C63000 CPU (PC, instruction code, data RAM address, data content and CPU register value) is stored into the trace memory at every CPU bus cycle. The trace memory has a capacity of 8,192 cycles, which can store the latest instructions up to 4,096 in 2 bus cycles instruction and 2,048 in 4 bus cycles instruction.

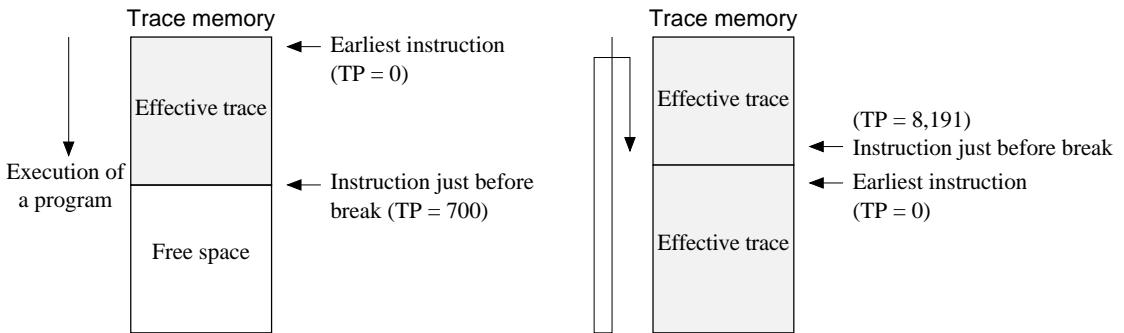
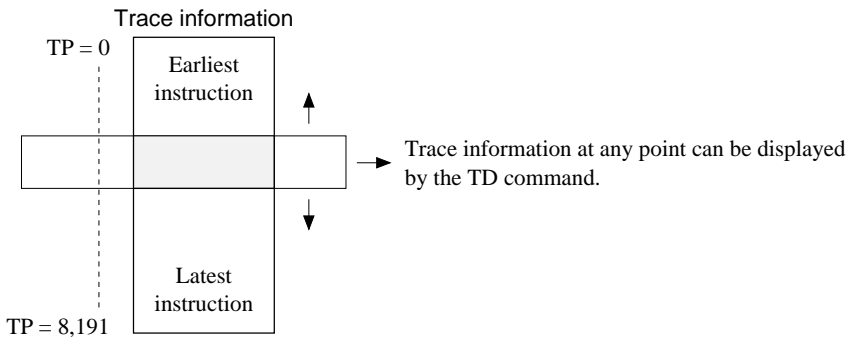

Fig. 5.7.1 Trace function

Figure 5.7.1 shows the trace function. When the trace memory is full, old information is erased and new information is overwritten. TP called trace pointer shows that the point of 0 means the earliest instruction and the break point means the latest information. The maximum value of the TP is 8,191.



## 5.8 Trace Mode

---

There are following three trace modes.

### (1) All bus cycle trace mode

In this trace mode, all bus cycles are traced during run emulation and step emulation until a break occurs.

### (2) Specified PC range trace mode

In this mode, bus cycles within the specified range (or outside the specified range) are traced during run emulation and step emulation until a break occurs. This function is useful for cases of tracing objective work data only or removing WAIT routine from the trace.

### (3) Single delay trigger

In this mode, starting a run emulation starts tracing all bus cycles. When the emulation hit the trace trigger condition, the trace continues for the specified bus cycles, and then it stops. The trace information is displayed after a break.

In the debugger, one of the above modes can be selected by the TM command.

## 5.9 Trace Trigger Point

---

In the S5U1C63000H2, a trace trigger point can be specified independent of breaking points. The trace trigger point is specified as the program counter conditions of the S1C63000 CPU. A low level pulse is output from the TRGOUT terminal with the timing of T3 upon coincidence of the specified value and the program counter. The information of the trace trigger point is also stored into the trace memory. In the single delay trigger mode, the trace trigger point becomes a condition for stopping the trace.

## 5.10 Coverage Function

---

The S5U1C63000H2 can retrieve and display the address information of the program accessed at the execution. The confirmation of portions whether failure analysis or debugging is completed or not can be done by checking the program through reference of the coverage information after running the program for a long time. This function is specified by the CV or CVC commands.

## 5.11 Measurement of Execution Time

---

The S5U1C63000H2 has a function to measure the time from start to break of target programs or to count the bus cycles. This function is set by the MD command.

### (1) Time measurement mode

- (a) Range of time measurement  
1  $\mu$ sec to  $1 \times (2^{31} - 1)$   $\mu$ sec ( $\approx 2,147$  sec  $\approx 36$  minutes)
- (b) Measurement error  
 $\pm 1$   $\mu$ sec
- (c) Units of time display  
Micro second ( $\mu$ sec)

### (2) Bus cycle count mode

- (a) Range of cycle measurement  
1 bus cycle to  $(2^{31} - 1)$  bus cycles ( $= 2 \times 10^9$  bus cycles)
- (b) Measurement error  
0 cycle

## 5.12 Self Diagnosis Function

In the S5U1C63000H2, it is possible to select whether the self diagnosis at power on is executed or not.

### (1) No self diagnosis mode (DSW8: on, factory setting)

When the DIP switch 8 on the front panel of the S5U1C63000H2 is set to on, the S5U1C63000H2 becomes ready to accept commands without the self diagnosis after power on.

### (2) Self diagnosis mode (DSW8: open)

When the switch is set to open, the S5U1C63000H2 execute following self diagnosis after power on, and then it becomes ready to accept commands.

- (a) ROM test  
Check-sum test of the firmware
- (b) RAM test  
Read/write test of the RAM in the S5U1C63000H2
- (c) Flash memory test  
Check sum test of the flash memory
- (d) Emulation test  
Tests the break function by executing a run emulation for a few steps on the emulation memory.

The self diagnosis takes about five minutes after power on.

If an error is displayed while testing, it is considered to be failure of the hardware. Please consult us.

## 5.13 Restrictions on Emulation

### (1) Timer operation in standby mode

In the emulation with the peripheral circuit board connected to the S5U1C63000H2, the S1C63000 CPU is ordinarily at the idle status (standby mode) as shown in Section 5.1. In the standby mode, the S5U1C63000H2 executes the monitor program and the peripheral circuit board is in stop status. The S5U1C63000H2 executes the target program by the G command and returns to the monitor program after a break occurs.

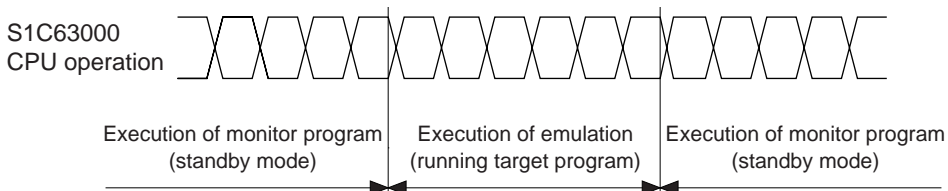

Fig. 5.13.1 Operation of S1C63000 CPU

In the models having a timer and a watch dog timer, the timer is operated only when the target program is executed if the timer is active. Therefore, in the single step operation, a real time counting cannot be done with the timers in the S1C63xxx.

**(2) Interrupt in standby mode**

In the standby mode, interrupt requests from the target system is reserved. The interrupt while the monitor program is being executed is accepted at the execution of the target program. For instance, when an interrupt request from the target system is generated while breaking, the interrupt is accepted immediately after the target program restarts if the interrupt is enabled in the S1C63000 CPU.

**(3) Interrupt at single step operation**

Interrupts during single step operation can be enabled or disabled using the MD command. Each operation is as follows.

- *When interrupt is enabled*

If an interruption request is generated while a target program step is executed by the S or N commands, the interrupt processing is done at the time of the instruction execution, and the execution stops after fetching the vector address of the interrupt. Therefore, next single step operation executes the interrupt handler routine. When the HALT or SLP instructions are executed by the S or N commands, the commands are executed until a interrupt is occurred. In this status, a forced break input from the host computer suspends the execution.

- *When interrupt is disabled*

Interrupt processing are not executed by the S command. Therefore, the execution of the HALT or SLP instructions is immediately suspended, and the program counter indicates an address next to the HALT or SLP instructions. The N command operates similar to the S command in the execution of the main routine, however, it enables interrupts regardless of the setting by the MD command in the execution of the sub-routine.

**(4) Data read from undefined RAM area**

When a data RAM (ROM) area or an I/O area that is not available in the actual IC chip is read, the read data becomes indefinite. Read data from the actual IC is also indefinite, however it is different from the S5U1C63000H2.

**(5) Detection of SP1 incorrect stack access**

It is possible to detect any incorrect stack access to out of SP1 area by specifying the SP1 area with the BSP command.

The S1C63000 CPU has a queue register and takes stack value in advance in order to make high speed process of the stacking operation for the CALR instruction and interrupts. Therefore, when a value is returned from the top address of the stack, it takes the stack value beyond the top address and write it into the queue register. This operation works without any problem, however, the queue register has an indefinite value. In order not to make this process incorrect access, it is necessary to add three addresses onto the real using SP1 area.

**(6) Data read break**

In the execution of "INT addr6" instruction, setting break on the data read condition may break program running, because dummy read cycle of a memory specified by addr6 operand is added. For instance, when the break at read cycle is set by the break data set command (BD), the dummy read hits the break condition.

**(7) Register (data) break**

The register (data) value after completion of the break operation may differ from the original setting register (data) condition for the break. For instance, in the timing chart to set sequentially 5 and 6 into the A register, if the A register is 5 as a register break condition;

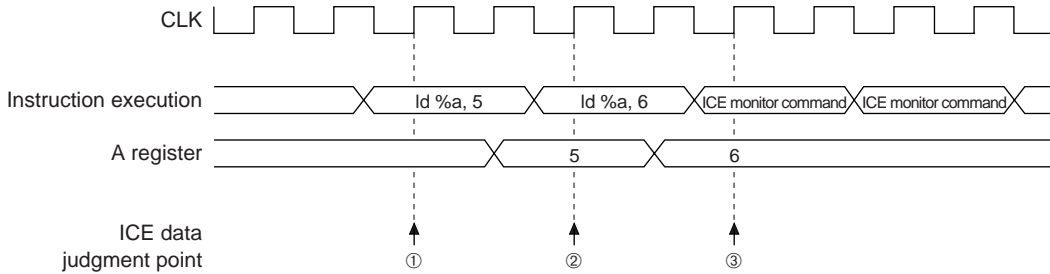

The S5U1C63000H2 judges the register data at the point of "↑", and judges that the A register is 5 at the point of ②. When the program is broken at this point, it has executed the next command of "ld %a, 6", therefore, the break is occurred after the A register is set to 6. This means that the A register content has been changed to 6 when the content is refereed after the break. This is also applied to the break by accessing to undefined area function.

**(8) Register (data) break and hardware interrupt**

The register (data) value after completion of the break operation may differ from the original setting register (data) condition for the break. Furthermore, when a hardware interrupt is occurred in this point, the break address shifts to the top address of the interrupt handler routine. For instance, in the timing chart to set sequentially 5 and 6 into the A register, if the A register is 5 as a register break condition, and a hardware interrupt is occurred while executing "ld %a, 5";

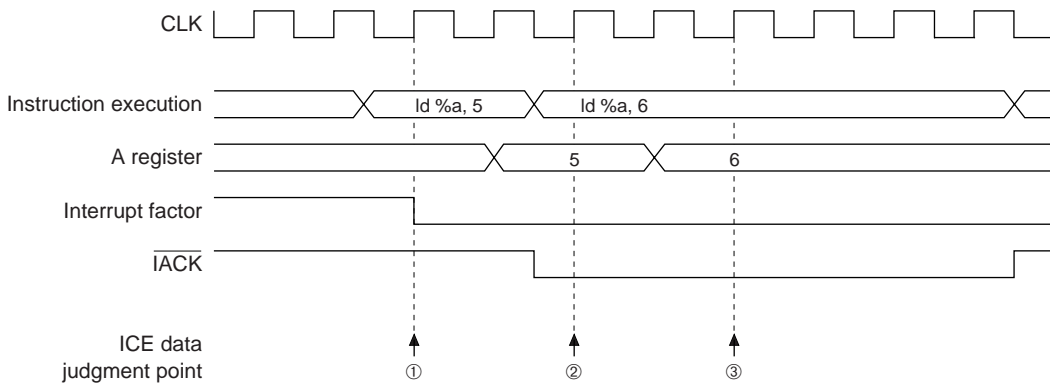

In the timing chart above, if the interrupt is occurred (at the falling edge) at the point of ①, the S1C63000 CPU outputs  $\overline{IACK}$  to show the execution of the interruption response cycle. The interrupt processing can not be stopped while this  $\overline{IACK}$  is at low level. Therefore, the S5U1C63000H2 can not stop the interrupt in spite of its judgment that the A register becomes 5 at the point of ② because the  $\overline{IACK}$  is at low level, and the break is occurred after jumping to the interrupt vector address.

# CHAPTER 6 NOTES ON USING

Pay attention to the following matters for proper use of the S5U1C63000H2.

## 6.1 Notes on Operations

---

### (1) Connection and disconnection between units

Make sure that the S5U1C63000H2 and the personal computer are off when installing the peripheral circuit board (S5U1C63xxxP), connecting cables and disconnecting them. Specially, the connection of the target cable with the power on may make permanent destruction of IC's inside due to its CMOS structure.

### (2) Power on, off

When the power of the S5U1C63000H2 is on again after off, remain off condition for 10 seconds or more. The power on without such interval may result in incorrect power-on-reset operation and/or working the circuit breaker of the S5U1C63000H2.

### (3) Peripheral circuit board (S5U1C63xxxP)

A peripheral circuit board is required for operation of the S5U1C63000H2. The S5U1C63000H2 package does not include peripheral circuit board that needs to be separately provided. If the S5U1C63000H2 is turned on without peripheral circuit board installed, the "HLT/SLP" LED on the front panel of the S5U1C63000H2 goes on and the LEDs to indicate the program counter value show 110H.

### (4) Over current protection

If the power of the S5U1C63000H2 is on under the condition that VDD and VSS are short-circuited on the target system, the power LED does not turn on due to cut off of the output current working the over current protection in the dedicated AC adapter. The circuit breaker cuts the power at the load current of 3 A or more on the target system.

## 6.2 Differences from Actual IC

---

### (1) Initialization of RAM

Data RAM of the actual IC becomes indefinite value, however, of the S5U1C63000H2 is initialized to 0AH. Therefore, the initialization must be done in the target program, and any program depending on the initial value must not be made.

### (2) Initialization of registers

In the actual IC, registers have indefinite values at power on and keep values prior to the reset except the program counter (PC), the interruption flag (I) and the extension flag (E). However, the S5U1C63000H2 is initialized to 0AH (4-bit), 0AAH (8-bit) and 0AAAAH (16-bit) at the power on and at the software reset by the command of the debugger. Because of this, each register must be initialized, and any program depending on the initial value must not be made. The reset switch on the peripheral circuit board and the hardware reset input from the I/O connector keep values prior to the reset as the actual IC.

### (3) Access to undefined area

In the S5U1C63000H2, the access to the undefined area causes break. However, the S5U1C63000H2 has RAM for the undefined area, and the break occurs after accessing to the undefined area, so that it can writes any value into the undefined area. If execution of the target program is restarted after the break by accessing to undefined area, it works with non-existing memory. Therefore, any program to read/write into the undefined area must not be made.

### (4) Data dump

The S5U1C63000H2 uses a peripheral circuit board clock for access to RAM, ROM, LCD and I/O area with the data dump command. When the I/O area is read in the target program, there may have a time delay until the correct value is obtained due to the parasitic capacitance and the pull-up/down resistors of each I/O terminal. Therefore, the value read on the target program may differ from the value read by the dump command.

# CHAPTER 7 MAINTENANCE AND WARRANTY

## 7.1 Diagnosis Test

---

The self diagnosis test is executed by setting SW8 of the DIP switch to OPEN and starting the debugger after power of the S5U1C63000H2 on.

```

Debugger for S1C63 Ver x.xx
Copyright(C) SEIKO EPSON CORP. xxxx
Connecting with ICE .....
DIAG test, please wait 5 min. .. done ← ①
Parameter file name      : xxxxxxxx.par
          Version        : xx
          Chip name      : xxxxx
CPU version              : x.x
PRC board version       : x.x
LCD board version       : x.x
EXT board version       : x.x
ICE hardware version    : x.x
ICE software version    : x.x
DIAG test               : OK.
Map ..... done
Initialize ..... done
>

```

When an error is detected, the error message is output at the point of ① instead of "done". If an error message is output, stop using the S5U1C63000H2 because it may have a hardware failure.

This diagnosis test takes approx. 5 minutes for completion because of its precise inspection. Even in the free run mode, it takes approx. 5 minutes for the self diagnosis test before the target program is executed.

## 7.2 Warranty

---

Please refer to the warranty card attached to the unit for the warranty details.

## CHAPTER 8 TROUBLE SHOOTING

Following shows some hardware errors and their possible causes.

- **A message of "connecting with ICE...failure" is displayed at the execution of the debugger.**
  - Is power of S5U1C63000H2 on ?
  - Is circuit breaker (CB) off ?
  - Is host cable connected correctly ?
  - Is DIP switch of S5U1C63000H2 set correctly ?
  - Is baud rate between host and ICE set correctly ?
  - Is target cable connected correctly ?
  - Is various board (peripheral circuit board, LCD board) inserted firmly ?
- **The circuit breaker (CB) operates and the power LED goes off when the S5U1C63000H2 power is turned on.**
  - Is target cable connected correctly ?
  - Is V<sub>DD</sub> or V<sub>SS</sub> short-circuited on a target ?

Refer to "S5U1C63000A Manual" for operations of the debugger.

# CHAPTER 9 SPECIFICATIONS OF LCD BOARD

## 9.1 Introduction

### 9.1.1 General description of LCD board

The LCD board provides on a board the peripheral circuits (LCD driver) of the S1C63 Family microcomputers other than the core CPU. The board can work as an emulator corresponding to each model of the S1C63 Family by installing into the S5U1C63000H2 along with a S1C63 Family peripheral circuit board (S5U1C63xxxP). This board may be set for each model by loading mask option data (generated by the function option generator) using the ICE command.

### 9.1.2 External view of LCD board

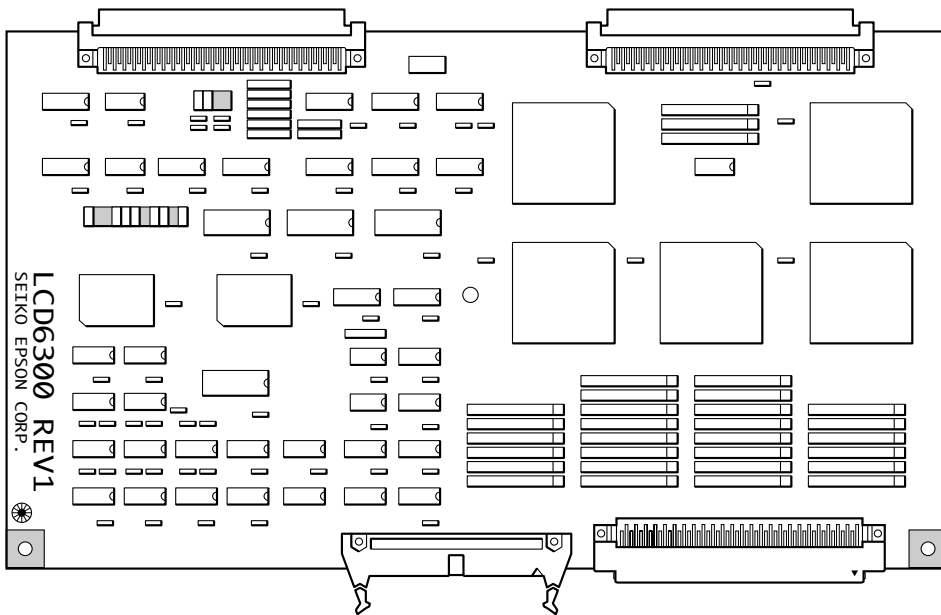

Fig. 9.1.2.1 External view of LCD board

## 9.2 Precautions on Using

---

Follow the precautions described below to ensure that the LCD board board is used properly. Note, however, that some functions described here may not be available with some models. For details, refer to the technical manual for each model.

### 9.2.1 Notes on operations

Always be sure to power off all connected equipment before connecting or disconnecting the cable.

### 9.2.2 Difference from an actual IC

It is necessary to well know following differences from an actual IC on functions and characteristics. Unless there are considered, successful operation on the S5U1C63000H2 with the LCD board may not be reproduced on the actual IC.

#### (1) Initialization

In the actual IC, contents of the segment memory are indefinite at system reset and the LCD drive waveform output is also indefinite in response to this. It means that the segment memory and the LCD drive waveform are coincident even though both are indefinite. However, in this board, the segment memory and the LCD drive waveform output are not coincident. Therefore, any initialization routine that surely clears (or sets) the segment memory after the system reset must be installed.

#### (2) LCD segment RAM (for models that have fixed assignment of LCD segments to memory bits)

In the actual IC, when reading a segment memory address that includes bits not assigned for LCD segment, the non-assigned bits are always read as 0. However, in this board, the non-assigned bits in the segment memory can be read and write as a memory. Therefore, when reading such address, the non-assigned bits in the word (4 bits) must be ignored.

#### (3) Power supply range in external LCD power mode

When the LCD power is supplied from an external source in the external LCD power mode, following voltage formula must be satisfied. These terminals are located in the connector of the peripheral circuit board.

- For models that use VSS as GND level  
 $VSS < VC1 < VC2 < VC3 < VC4 < VC5 \leq VDD (= +5 V)$
- For models that use VDD as GND level  
 $VSS < VL5 < VL4 < VL3 < VL2 < VL1 \leq VDD (= +5 V)$

#### (4) Drive capability of SEG and COM terminals

The output drive capability of the SEG and COM terminals in this board is higher than those of the actual IC. The S5U1C63000H2 can not be used for evaluation of the electrical characteristics. The system should be design in consideration of the electrical characteristics described on the technical manual of each model.

#### (5) LCD drive voltage

The LCD drive voltage in this board may differ from that of the actual IC.

### 9.3 Connection with Target System

Use the connection cables (100-pin/50-pin × 2 flat type, 34-pin flat type) supplied for the connection between the LCD board and target systems.

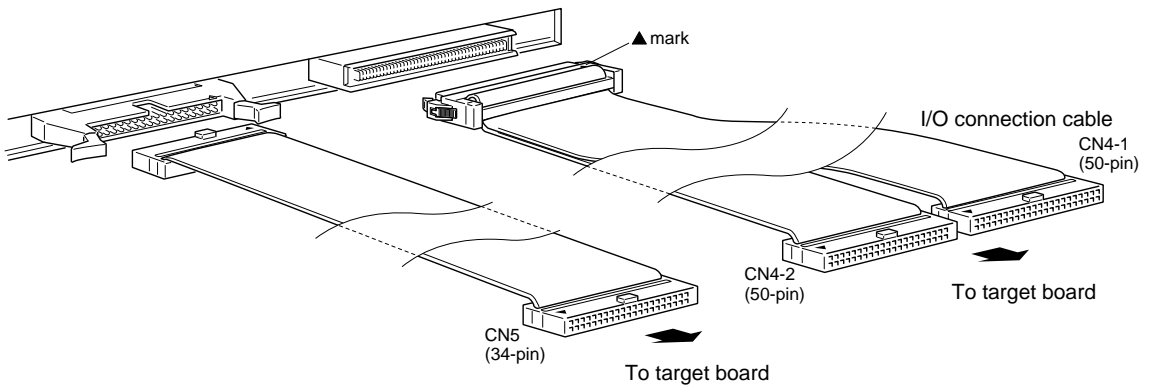

Fig. 9.3.1 Connection with target system

## ● Pin layout of connectors

*CN-4 connectors (100-pin/50-pin × 2 flat type)*

CN4-1 connector			CN4-2 connector		
No.	Name	Function	No.	Name	Function
1	COM0	COM0	1	SEG42	SEG42
2	COM1	COM1	2	SEG43	SEG43
3	COM2	COM2	3	SEG44	SEG44
4	COM3	COM3	4	SEG45	SEG45
5	COM4	COM4	5	SEG46	SEG46
6	COM5	COM5	6	SEG47	SEG47
7	COM6	COM6	7	SEG48	SEG48
8	COM7	COM7	8	SEG49	SEG49
9	SEG0	SEG0	9	SEG50	SEG50
10	SEG1	SEG1	10	SEG51	SEG51
11	SEG2	SEG2	11	SEG52	SEG52
12	SEG3	SEG3	12	SEG53	SEG53
13	SEG4	SEG4	13	SEG54	SEG54
14	SEG5	SEG5	14	SEG55	SEG55
15	SEG6	SEG6	15	SEG56	SEG56
16	SEG7	SEG7	16	SEG57	SEG57
17	SEG8	SEG8	17	SEG58	SEG58
18	SEG9	SEG9	18	SEG59	SEG59
19	SEG10	SEG10	19	SEG60	SEG60
20	SEG11	SEG11	20	SEG61	SEG61
21	SEG12	SEG12	21	SEG62	SEG62
22	SEG13	SEG13	22	SEG63	SEG63
23	SEG14	SEG14	23	SEG64	SEG64
24	SEG15	SEG15	24	SEG65	SEG65
25	SEG16	SEG16	25	SEG66	SEG66
26	SEG17	SEG17	26	SEG67	SEG67
27	SEG18	SEG18	27	SEG68	SEG68
28	SEG19	SEG19	28	SEG69	SEG69
29	SEG20	SEG20	29	SEG70	SEG70
30	SEG21	SEG21	30	SEG71	SEG71
31	SEG22	SEG22	31	SEG72	SEG72
32	SEG23	SEG23	32	SEG73	SEG73
33	SEG24	SEG24	33	SEG74	SEG74
34	SEG25	SEG25	34	SEG75	SEG75
35	SEG26	SEG26	35	SEG76	SEG76
36	SEG27	SEG27	36	SEG77	SEG77
37	SEG28	SEG28	37	SEG78	SEG78
38	SEG29	SEG29	38	SEG79	SEG79
39	SEG30	SEG30	39		Cannot be connected
40	SEG31	SEG31	40		Cannot be connected
41	SEG32	SEG32	41		Cannot be connected
42	SEG33	SEG33	42		Cannot be connected
43	SEG34	SEG34	43		Cannot be connected
44	SEG35	SEG35	44		Cannot be connected
45	SEG36	SEG36	45		Cannot be connected
46	SEG37	SEG37	46		Cannot be connected
47	SEG38	SEG38	47		Cannot be connected
48	SEG39	SEG39	48		Cannot be connected
49	SEG40	SEG40	49		Cannot be connected
50	SEG41	SEG41	50		Cannot be connected

*CN-5 connector (34-pin × 2 flat type)*

CN5 connector		
No.	Name	Function
1	COM0	COM0
2	COM1	COM1
3	COM2	COM2
4	COM3	COM3
5	COM4	COM4
6	COM5	COM5
7	COM6	COM6
8	COM7	COM7
9	COM8	COM8
10	COM9	COM9
11	COM10	COM10
12	COM11	COM11
13	COM12	COM12
14	COM13	COM13
15	COM14	COM14
16	COM15	COM15
17	COM16	COM16
18	COM17	COM17
19	COM18	COM18
20	COM19	COM19
21	COM20	COM20
22	COM21	COM21
23	COM22	COM22
24	COM23	COM23
25	COM24	COM24
26	COM25	COM25
27	COM26	COM26
28	COM27	COM27
29	COM28	COM28
30	COM29	COM29
31	COM30	COM30
32	COM31	COM31
33		Cannot be connected
34		Cannot be connected

Note that some pin names are not existed in the actual IC depending on the model.

The COM0–COM7 terminals are available in the both connectors CN4-1 and CN5, either can be used.

## 9.4 *Product Specifications*

---

Following shows the specifications of the LCD board components.

- **LCD board**

Dimension: 254 mm (wide) × 144.8 mm (depth) × 13 mm (height) (including screws)  
Weight: Approx. 220 g  
Power supply: DC 5 V ±5%, less than 1 A (supplied from S5U1C63000H2 main unit)

- **LCD cable**

Onboard connector: KEL8830E-100-170L  
3M3431-5002LCSC

# EPSON International Sales Operations

---

## AMERICA

---

### EPSON ELECTRONICS AMERICA, INC.

#### - HEADQUARTERS -

150 River Oaks Parkway  
San Jose, CA 95134, U.S.A.  
Phone: +1-408-922-0200 Fax: +1-408-922-0238

#### - SALES OFFICES -

##### West

1960 E. Grand Avenue  
El Segundo, CA 90245, U.S.A.  
Phone: +1-310-955-5300 Fax: +1-310-955-5400

##### Central

101 Virginia Street, Suite 290  
Crystal Lake, IL 60014, U.S.A.  
Phone: +1-815-455-7630 Fax: +1-815-455-7633

##### Northeast

301 Edgewater Place, Suite 120  
Wakefield, MA 01880, U.S.A.  
Phone: +1-781-246-3600 Fax: +1-781-246-5443

##### Southeast

3010 Royal Blvd. South, Suite 170  
Alpharetta, GA 30005, U.S.A.  
Phone: +1-877-EEA-0020 Fax: +1-770-777-2637

## EUROPE

---

### EPSON EUROPE ELECTRONICS GmbH

#### - HEADQUARTERS -

Riesstrasse 15  
80992 Munich, GERMANY  
Phone: +49-(0)89-14005-0 Fax: +49-(0)89-14005-110

#### SALES OFFICE

Altstadtstrasse 176  
51379 Leverkusen, GERMANY  
Phone: +49-(0)2171-5045-0 Fax: +49-(0)2171-5045-10

#### UK BRANCH OFFICE

Unit 2.4, Doncastle House, Doncastle Road  
Bracknell, Berkshire RG12 8PE, ENGLAND  
Phone: +44-(0)1344-381700 Fax: +44-(0)1344-381701

#### FRENCH BRANCH OFFICE

1 Avenue de l'Atlantique, LP 915 Les Conquerants  
Z.A. de Courtaboeuf 2, F-91976 Les Ulis Cedex, FRANCE  
Phone: +33-(0)1-64862350 Fax: +33-(0)1-64862355

#### BARCELONA BRANCH OFFICE

**Barcelona Design Center**  
Edificio Testa, Avda. Alcalde Barrils num. 64-68  
E-08190 Sant Cugat del Vallès, SPAIN  
Phone: +34-93-544-2490 Fax: +34-93-544-2491

## ASIA

---

### EPSON (CHINA) CO., LTD.

23F, Beijing Silver Tower 2# North RD DongSanHuan  
ChaoYang District, Beijing, CHINA  
Phone: 64106655 Fax: 64107319

#### SHANGHAI BRANCH

4F, Bldg., 27, No. 69, Gui Qing Road  
Caohejing, Shanghai, CHINA  
Phone: 21-6485-5552 Fax: 21-6485-0775

### EPSON HONG KONG LTD.

20/F., Harbour Centre, 25 Harbour Road  
Wanchai, Hong Kong  
Phone: +852-2585-4600 Fax: +852-2827-4346  
Telex: 65542 EPSCO HX

### EPSON TAIWAN TECHNOLOGY & TRADING LTD.

10F, No. 287, Nanking East Road, Sec. 3  
Taipei  
Phone: 02-2717-7360 Fax: 02-2712-9164  
Telex: 24444 EPSONTB

#### HSINCHU OFFICE

13F-3, No. 295, Kuang-Fu Road, Sec. 2  
HsinChu 300  
Phone: 03-573-9900 Fax: 03-573-9169

### EPSON SINGAPORE PTE., LTD.

No. 1 Temasek Avenue, #36-00  
Millenia Tower, SINGAPORE 039192  
Phone: +65-337-7911 Fax: +65-334-2716

### SEIKO EPSON CORPORATION KOREA OFFICE

50F, KLI 63 Bldg., 60 Yoido-dong  
Youngdeungpo-Ku, Seoul, 150-763, KOREA  
Phone: 02-784-6027 Fax: 02-767-3677

### SEIKO EPSON CORPORATION

#### ELECTRONIC DEVICES MARKETING DIVISION

##### Electronic Device Marketing Department

##### IC Marketing & Engineering Group

421-8, Hino, Hino-shi, Tokyo 191-8501, JAPAN  
Phone: +81-(0)42-587-5816 Fax: +81-(0)42-587-5624

##### ED International Marketing Department Europe & U.S.A.

421-8, Hino, Hino-shi, Tokyo 191-8501, JAPAN  
Phone: +81-(0)42-587-5812 Fax: +81-(0)42-587-5564

##### ED International Marketing Department Asia

421-8, Hino, Hino-shi, Tokyo 191-8501, JAPAN  
Phone: +81-(0)42-587-5814 Fax: +81-(0)42-587-5110

**S5U1C63000H2 Manual**  
(S1C63 Family In-Circuit Emulator)

**SEIKO EPSON CORPORATION**  
ELECTRONIC DEVICES MARKETING DIVISION

■ EPSON Electronic Devices Website

<http://www.epsondevice.com>